



Serie • Series

SP

*BOMBAS MULTICELULARES AUTOASPIRANTES DE CANAL LATERAL*

*SIDE CHANNEL MULTISTAGE SELPRIMING PUMPS*

*POMPES MULTICELLULAIRES AUTOAMORÇANTES A CANAL LATERAL*



pumps

pumpen

**azcue**

bombas

pompes



REF. SP1/03

*Aplicaciones  
diversas*

*Some  
applications*

*Diverses  
aplicaciones*





## Nomenclatura / Description / Denomination

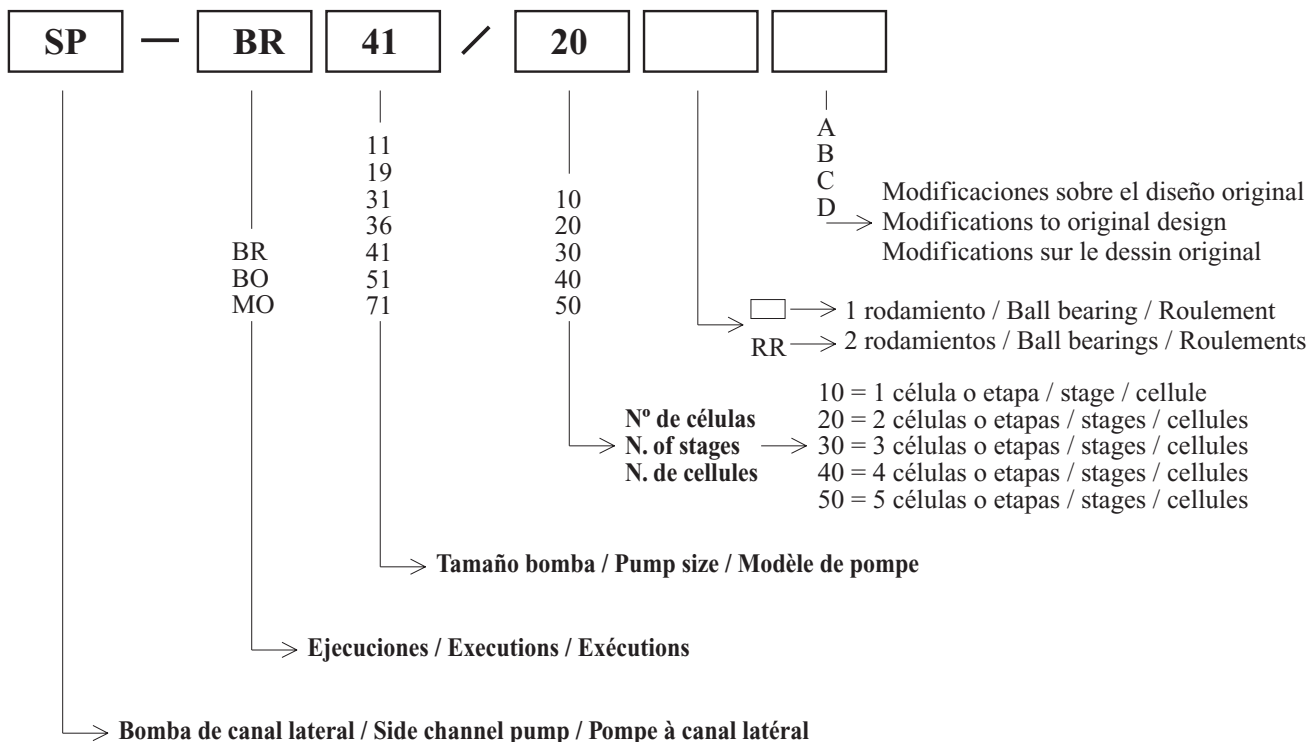

### EJECUCIONES / EXECUTIONS / EXÉCUTIONS

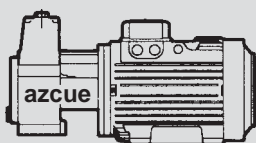

Tipo / Type MA  
Fig. 1

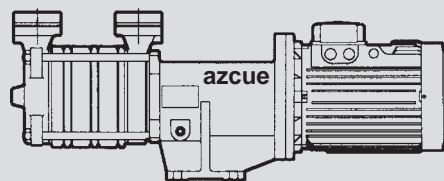

Tipo / Type MO  
Fig. 2

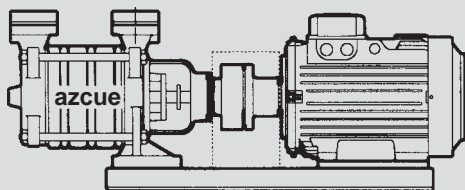

Tipo / Type BO  
Fig. 3

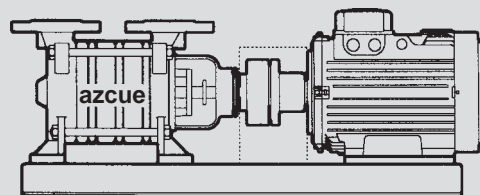

Tipo / Type BR  
Fig. 4



**FUNCIONAMIENTO Y GENERALIDADES**  
Las bombas de "canal lateral", también llamadas de "anillo líquido", poseen la particularidad de ser capaces de separar en su interior el líquido y el aire de una emulsión.

Este efecto se consigue gracias a la acción conjunta del (los) impulsor (es) de palas radiales con la forma y situación de los canales y conductos de los difusores donde va(n) alojado(s). Por ello, éstas bombas son autoaspirantes, es decir, capaces de cebarse por sí solas, pudiendo además bombear permanentemente líquidos con fuerte tenencia de aire u otros gases.

Al girar el impulsor dentro de los dos difusores o piezas intermedias, la forma y situación del canal de impulsión, hace que el fluido cambie permanentemente de dirección, saliendo y volviendo al impulsor; ésta circunstancia, produce un aumento progresivo de la presión en el fluido, alcanzando valores elevados con respecto a otros diseños.

El diseño multicelular permite el montaje de una a varias células o etapas, con lo cual, la presión final de la bomba, será igual al producto del número de células, por la presión obtenida en cada una de ellas.

La unión de ambas circunstancias, permite obtener elevadas presiones de descarga a velocidades moderadas y con un número mucho más reducido de células que una bomba centrífuga multicelular.

**CARACTERISTICAS CONSTRUCTIVAS**

**Presiones máximas de impulsión.**

Tipos MO, BO: 10 bar (1 Mpa).

Tipos BR: 16 bar (1,6 Mpa).

La presión de impulsión, se entiende como la suma de la presión de aspiración y la presión diferencial generada por la bomba.

**Temperatura máxima del fluido.**

Versión standard: 90° C.

Bajo demanda: 130° C.

**Cierre del eje.**

Versión standard: Cierre mecánico sin goteo.

Bajo demanda: Empaquetadura.

**Sentido de giro visto desde el motor.**

Versión standard: A derechas.

Bajo demanda: A izquierdas.

**OPERATION AND GENERALITIES**

The side channel pumps, also called liquid ring pumps, are able to separate air and liquid from a emulsion. This action is achieved grace to its radial vane impellers and side channels or difuser holes.

These selfpriming pump have a high priming capacity, being able to pump liquid with high air or gas content.

As the impeller rotates between two difusers, the discharge channel shape and location changes continuously the fluid direction, going out and back from the impeller. In this way, the fluid pressure increases, achieving high discharge pressures in comparisson with other pump designs.

The multistage design enables one or several stages assembly. The discharge pressure is directly related to the number of stages.

Therefore, the side channel pumps achieve high discharge pressures at low rotating speeds and with much less stages than multistage centrifugal pumps.

**CONSTRUCTIVE FEATURES**

**Maximum discharge pressures.**

Types MO, BO: 10 bar (1 Mla).

Types BR: 16 bar (1,6 Mla).

The discharge pressure is the suction pressure plus the manometric pressure created by the pump.

**Maximum fluid temperature.**

Standard version: 90° C.

Specially required: 130° C.

**Shaft seal.**

Standard version: Leakless mechanical seal.

Specially required: Soft packing.

**Rotating sense view from motor.**

Standard option: Clockwise.

Specially required: Anticlockwise.

**FONCTIONNEMENT ET GENERALITÉS**

Les pompes à "canal latéral", appelées également pompes à "anneau liquide", possèdent la particularité de pouvoir séparer dans leur structure interne le liquide de l'air d'une émulsion.

On obtient cet effet grâce à l'action conjuguée de(s) l'impulseur (s) des pales radiales et de la forme et emplacement des canaux et conduits des diffuseurs où l' (les) impulseur (s) est (sont) logé (s).

Pour cela, ces pompes sont autoamorçantes, c'est-à-dire capables de s'auto-amorcer et pouvant en outre pomper en permanence des liquides contenant une forte quantité d'air ou autres gas.

Quand l'impulseur tourne à l'intérieur des deux diffuseurs ou pièces intermédiaires, la forme et l'emplacement du canal d'impulsion, font que le fluide change en permanence de direction, sortant et revenant à l'impulseur; cette situation provoque une augmentation progressive de la pression dans le fluide, atteignant des valeurs élevées par rapport à d'autres conceptions.

La conception multicellulaire permet le montage d'une à plusieurs cellules ou étages ce qui fait que la pression finale de la pompe sera égale au produit du nombre de cellules de par la pression obtenue dans chacune d'elles.

La réunion de ces deux conditions permet d'obtenir des pressions élevées de déchargement à des vitesses modérées, ceci en utilisant un nombre de cellules beaucoup plus réduit qu'une pompe centrifuge multicellulaire.

**CARACTERISTIQUES TECHNIQUES**

**Pressions maximum de refoulement.**

Types MO, BO: 10 bar (1 Mpa).

Types BR: 16 bar (1,6 Mpa).

On entend par la pression de refoulement, la somme de la pression d'aspiration et de la pression différentielle produite par la pompe.

**Température maximum du fluide.**

Versión standard: 90° C.

À la demande: 130° C.

**Fermeture de l'arbre.**

Versión standard: Étanchéité mécanique sans fuite.

À la demande: Avec presse étoupe.

**Sens de rotation vu du moteur.**

Versión standard: À droite.

À la demande: À gauche.

MATERIALES / MATERIALS / MATERIAUX		
Elemento / Part / Element	A	B
Eje Shaft Arbre	Ac. inox/St. steel X5CrNiMo 18 10 (Aisi 316)	Ac. inox/St. steel X5CrNiMo 18 10 (Aisi 316)
Rodete Impeller Roue	Aluminium-Bronze G-CuAl10Ni	Aluminium-Bronze G-CuAl10Ni
Cuerpos o cabezas de aspiración-impulsión Suction/Discharge casings Corps our têtes d'aspiration/impulsion	GG25	Bronze/Bronze G-CuSn5ZnPb (Rg5) G-CuSn10
Difusores o piezas intermedias Diffuser Diffuseurs ou pièces intermédiaires	GG25	Bronze / Bronze G-CuSn7ZnPb

**Materiales.**

Bajo demanda se pueden fabricar los distintos componentes en hierro fundido nodular, acero inoxidable, etc.

**Aplicaciones.**

El fluido a bombear debe ser limpio y exento de partículas sólidas abrasivas.

Las bombas autoaspirantes de "canal lateral" serie SP destacan entre otras por las siguientes cualidades:

- Capacidad de bombear líquidos con fuerte tenencia de aire.

**Materials.**

The pumps can also be manufactured in different materials as nodular cast iron, stainless, etc if required.

**Applications.**

The pumped fluid must be clean and without abrasive solid particles.

The side channel selfpriming pumps SP series have among other the following features:

- Capacity to pump liquid with air content.
- Excellent selfpriming capacity.
- Low NPSH required.

**Materiaux.**

À la demande, on peut fabriquer les composants distincts en fonte nodulaire, acier inoxydable, etc.

**Applications.**

Le fluide à pomper doit être propre et sans particules solides abrasives.

Les pompes autoamorçantes à "canal latéral" série SP se distinguent des autres par les qualités suivantes:



- Excelente capacidad de autocebado.
- Bajo NPSH requerido.
- Posibilidad de obtener elevadas presiones de impulsión, con un número bajo de células o etapas.

Por ello abarcan un amplio abanico de aplicaciones tales como el bombeo de fluidos que por causa de la temperatura o su naturaleza, tengan una tensión de vapor elevada o sean muy volátiles. En caudales hasta 12 m<sup>3</sup>/h y presiones de hasta 8 bar aproximadamente, son en muchas ocasiones una alternativa ventajosa a las bombas centrifugas.

Relación parcial de sectores y servicios de aplicación.

**Industria en general.**

- Bombeo de combustible, gasolina, nafta, keroseno, gas-oil.
- Alimentación de calderas.
- Extracción de condensados.
- Bombeo de productos químicos, fluidos emulsionados, etc.

Y en general, todo tipo de aplicaciones con fluidos limpios y en condiciones de aspiración difíciles.

**Marina.**

- Servicios sanitarios de agua dulce y salada a bordo.
- Circulación de agua caliente sanitaria.
- Extracción de condensado en generadores de agua dulce.

- High discharge heads with very few stages. Therefore, these pumps cover a wide range of applications as high temperature fluids, high vapour tension liquids or volatile liquids.
- For capacities up to 12 m<sup>3</sup>/h and 8 bar pressure, they are many times more economical than centrifugal pumps.

Short list of application fields and services.

**Industry in general.**

- Fuel, petrol, nafta, kerosene, diesel-oil, pumping.
  - Boiler feeding.
  - Condensed water extraction.
  - Chemical products, emulsificated fluids, etc.
- In general, all kind of clean liquids with difficult suction conditions.

**Marine.**

- Fresh water and sea water sanitary services.
- Sanitary hot water circulation.
- Condensed water extraction on fresh water generators.

- Capacité de pomper des liquides contenant une forte quantité d'air.
- Excellente capacité d'auto-amorçage.
- Bas NPSH requis.
- Possibilité d'obtenir des pressions élevées de refoulement avec un faible nombre de cellules ou étapes.

Pour cela, les pompes autoamorçantes couvrent un large éventail d'applications telles que le pompage de fluides qui en raison de la température ou de leur nature, ont une tension de vapeur élevée ou qui sont très volatils. Pour des débits allant jusqu'à 12 m<sup>3</sup>/h et des pressions allant jusqu'à 8 bar environ, elles constituent dans de nombreuses occasions une alternative avantageuse aux pompes centrifuges.

Liste partielle des secteurs et services d'application.

**Industrie général.**

- Pompage de combustibles, essence, nafta, kérosène, gas-oil.
- Alimentation des chaudières.
- Extraction des condensat.

Et en général, toutes sortes d'applications avec des fluides propres et dans des conditions d'aspiration difficiles.

**Marine.**

- Services sanitaires d'eau douce et salée à bord.
- Circulation d'eau chaude sanitaire.
- Extraction de condensat dans les générateurs d'eau douce.

## Tipo / Type MA-80

### Grupo electrobomba / Electropump set / Groupe electropompe 2850/3450 r.p.m.

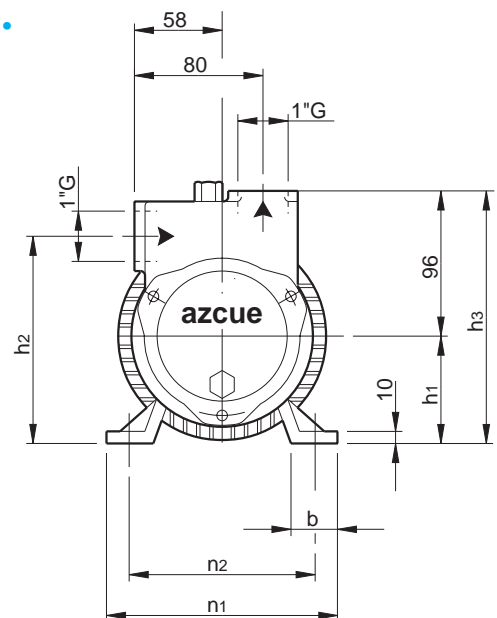
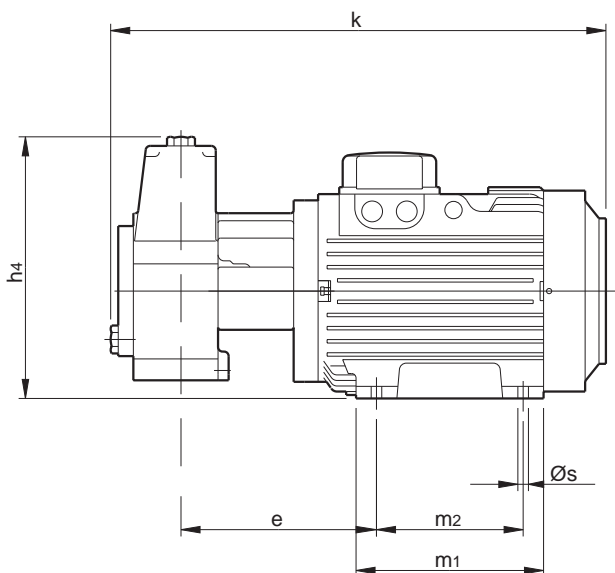

Motor	h1	h2	h3	h4	m1	m2	n1	n2	b	s	e	k	kg
0.55 KW	71	137	167	173	112	90	135	112	20	7	126	340	13
0.9 KW	80	146	176	182	127	100	154	125	30	9	132	365	15

50 Hz								
Q (m <sup>3</sup> /h)								
0,3	0,6	0,9	1,2	1,5	1,8	2,1	2,4	3
H (m)								
46	42	38	34	30	26	22	18	10
0,55 KW 2850 rpm.								

60 Hz				
Q (m <sup>3</sup> /h)				
1	1,4	1,9	2,6	3,3
H (m)				
60	50	40	30	20
0,9 KW 3450 rpm.				



50 Hz 1.450 r.p.m. t/min.

Diagramas de características.

De acuerdo a ISO 2548 clase C.

Performance curves.

In accordance with ISO 2548 C class.

Diagrammes de caractéristiques.

Selon ISO 2548 classe C.

Tamaño/Size/Modèle 11/...

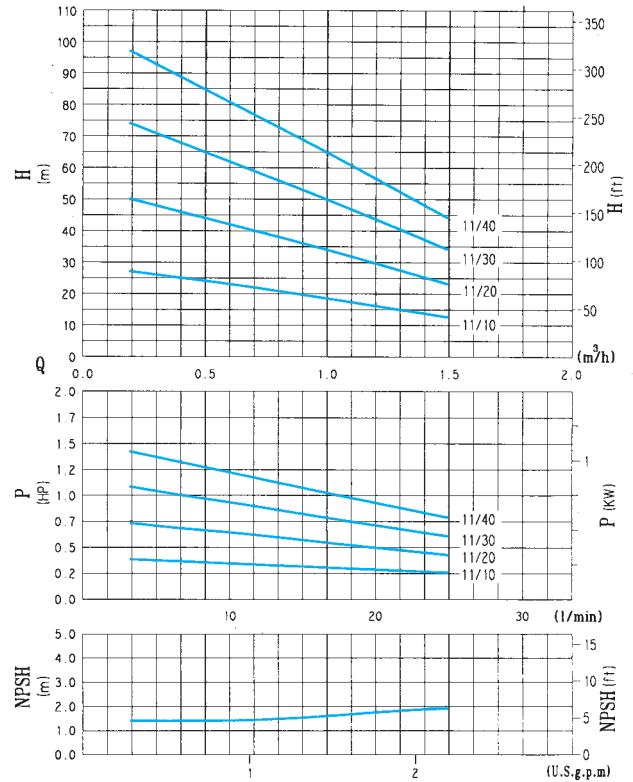

Ref.: DC-1100-1500 B

Tamaño/Size/Modèle 19/...

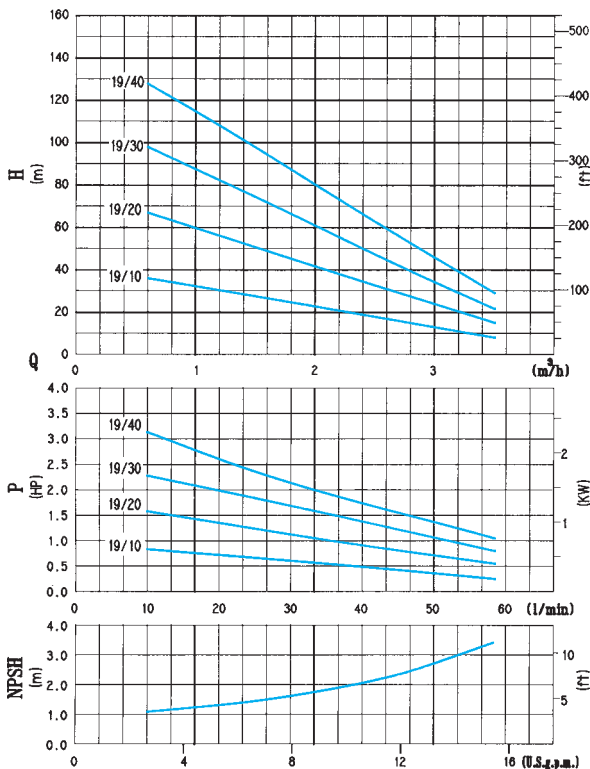

Ref.: DC-1900-1500

Tamaño/Size/Modèle 31/...

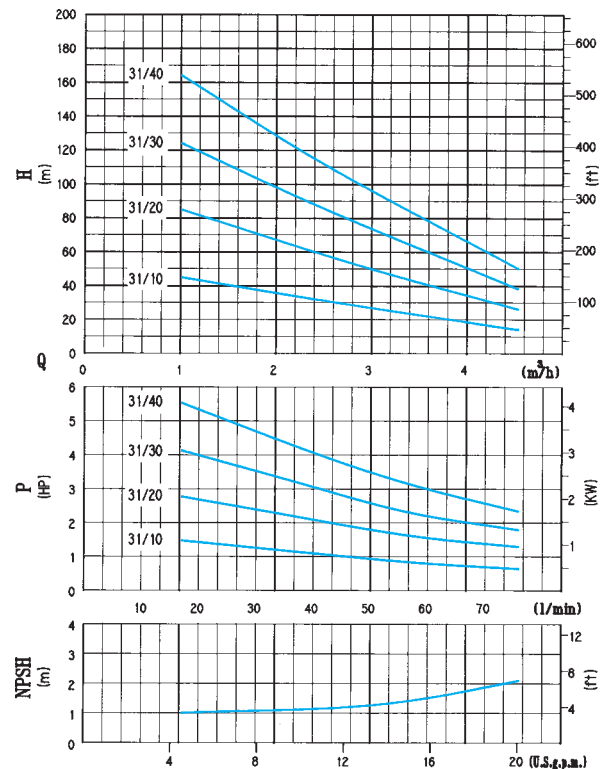

Ref.: DC-3100-1500



Tamaño/Size/Modèle 36/...

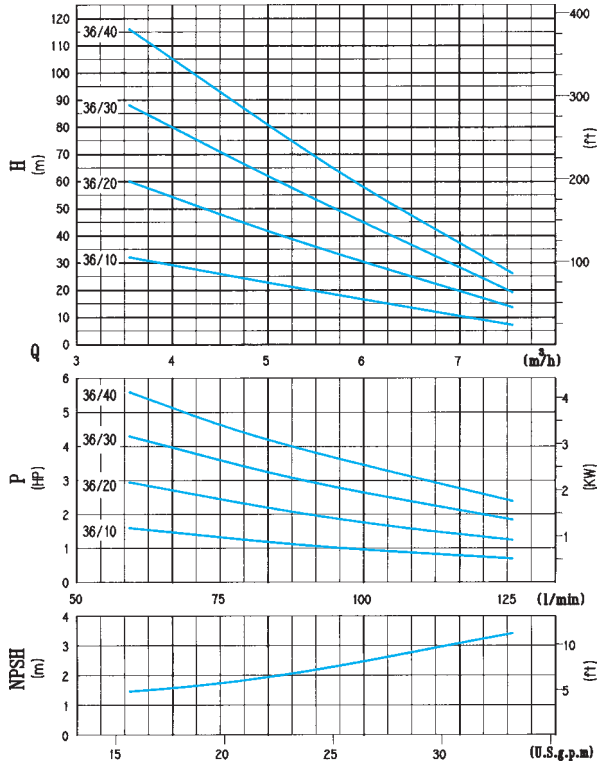

Ref.: DC-3600-1500

Tamaño/Size/Modèle 41/...

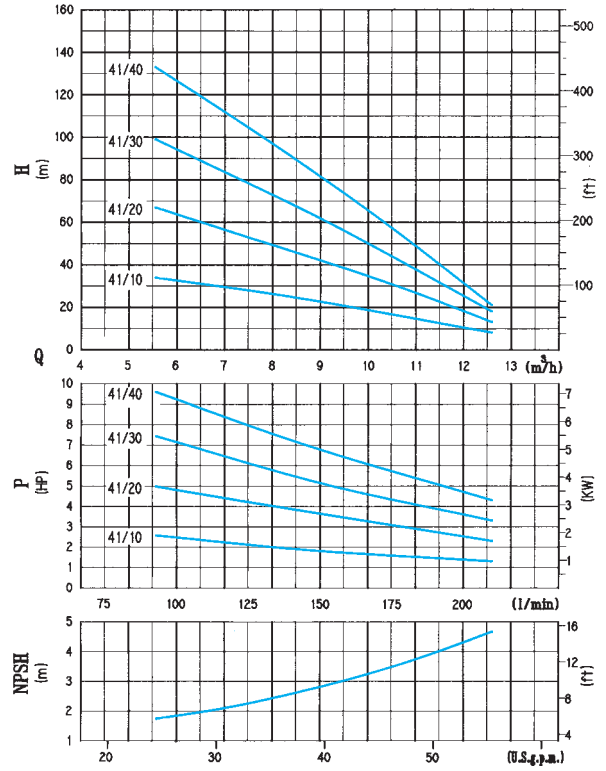

Ref.: DC-4100-1500

Tamaño/Size/Modèle 51/...

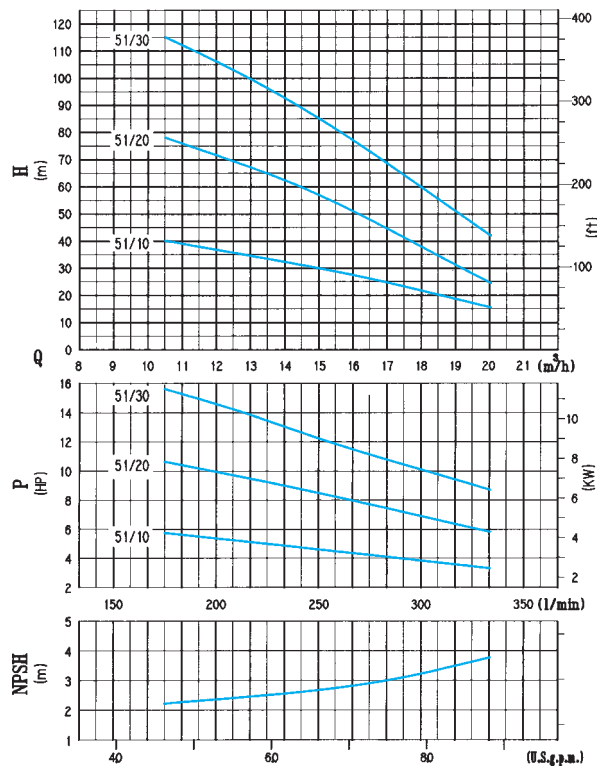

Ref.: DC-5100-1500

Tamaño/Size/Modèle 71/...

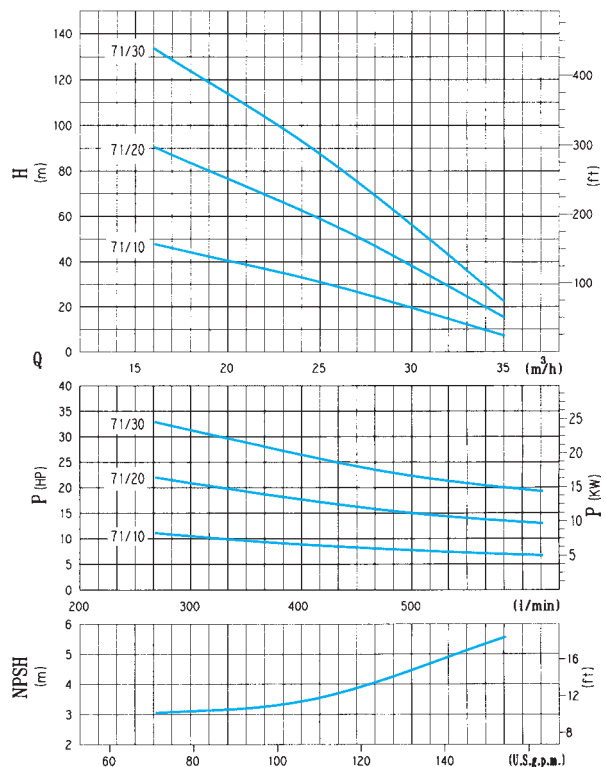

Ref.: DC-7100-1500



**60 Hz 1.750 r.p.m. t/min.**

**Diagramas de características.**

De acuerdo a ISO 2548 clase C.

**Performance curves.**

In accordance with ISO 2548 C class.

**Diagrammes de caractéristiques.**

Selon ISO 2548 classe C.

**Tamaño/Size/Modèle 11/...**

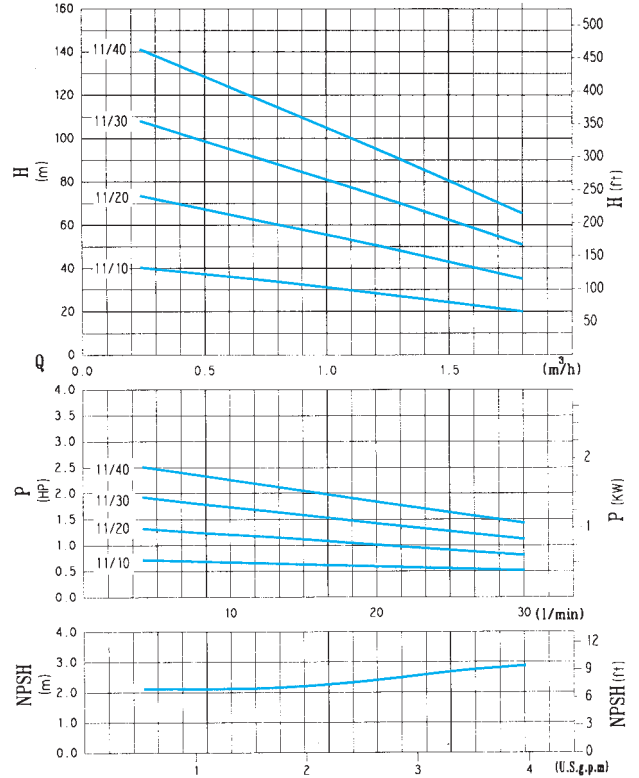

Ref.: DC-1100-180 B

**Tamaño/Size/Modèle 19/...**

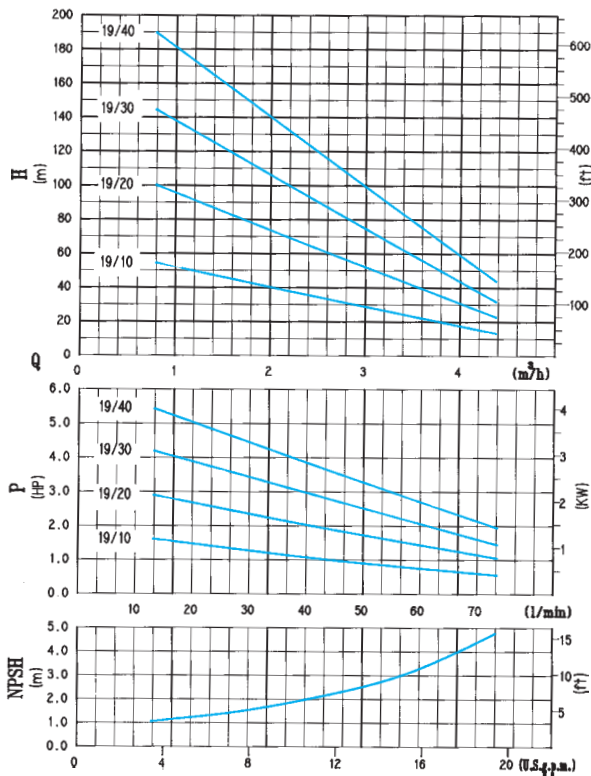

Ref.: DC-1900-1800

**Tamaño/Size/Modèle 31/...**

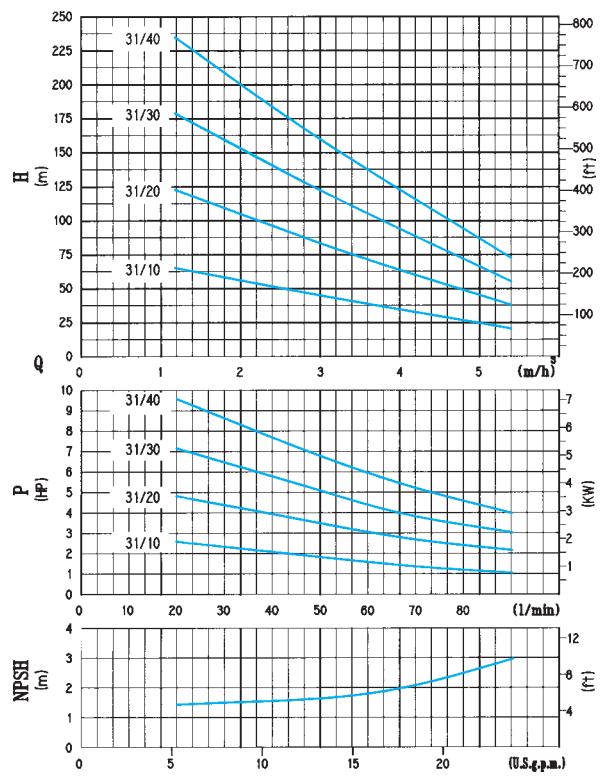

Ref.: DC-3100-1800





Tamaño/Size/Modèle 36/...

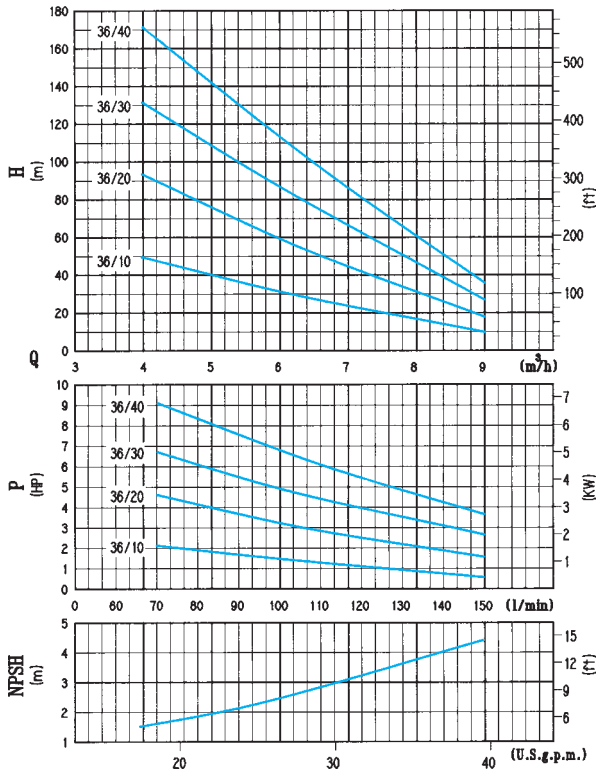

Ref.: DC-3600-1800

Tamaño/Size/Modèle 41/...

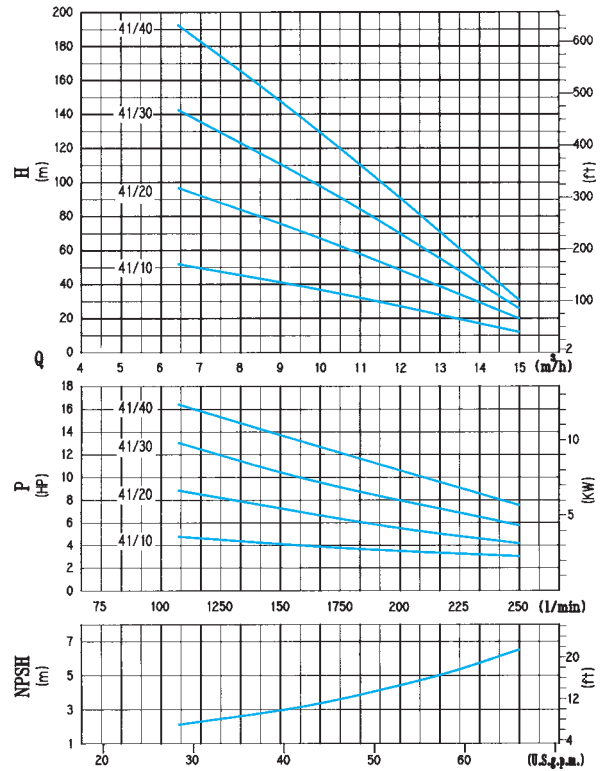

Ref.: DC-4100-1800

Tamaño/Size/Modèle 51/...

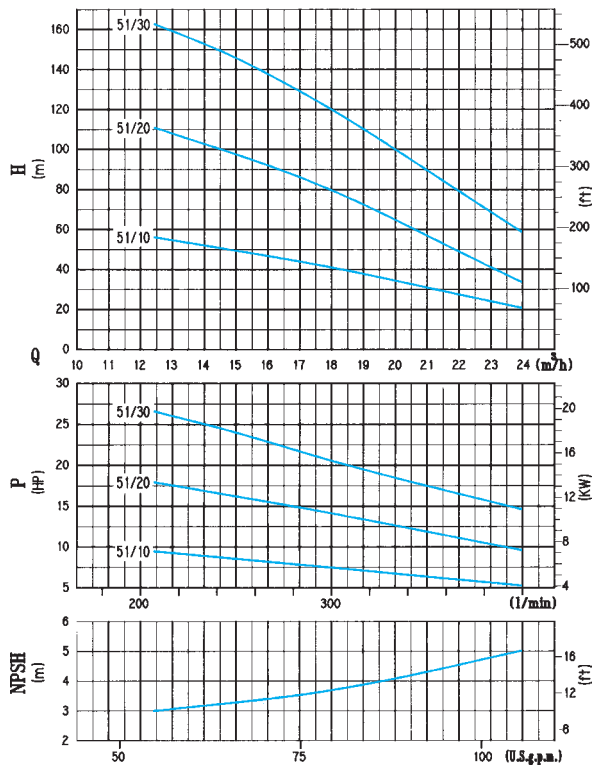

Ref.: DC-5100-1800

Tamaño/Size/Modèle 71/...

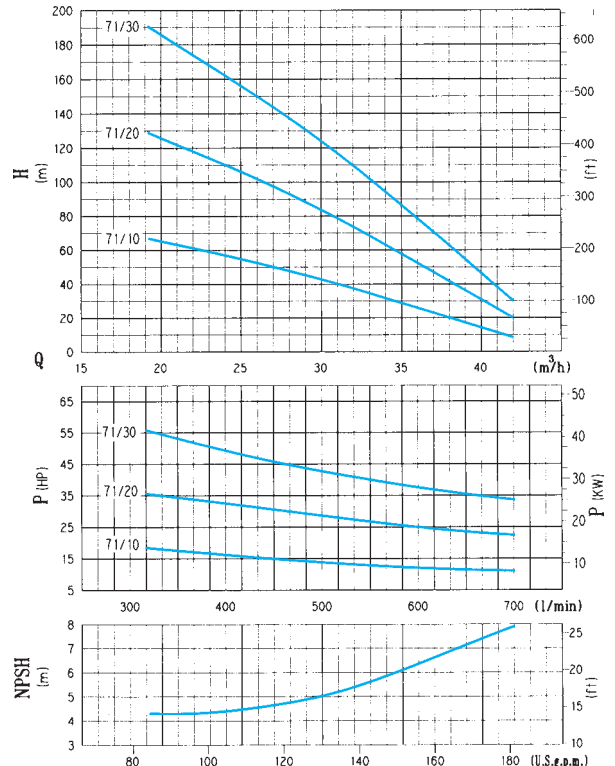

Ref.: DC-7100-1800



# Serie MO/MO series

## Grupo electrobomba / Electropump set / Groupe electropompe

### 1450/1750 r.p.m.

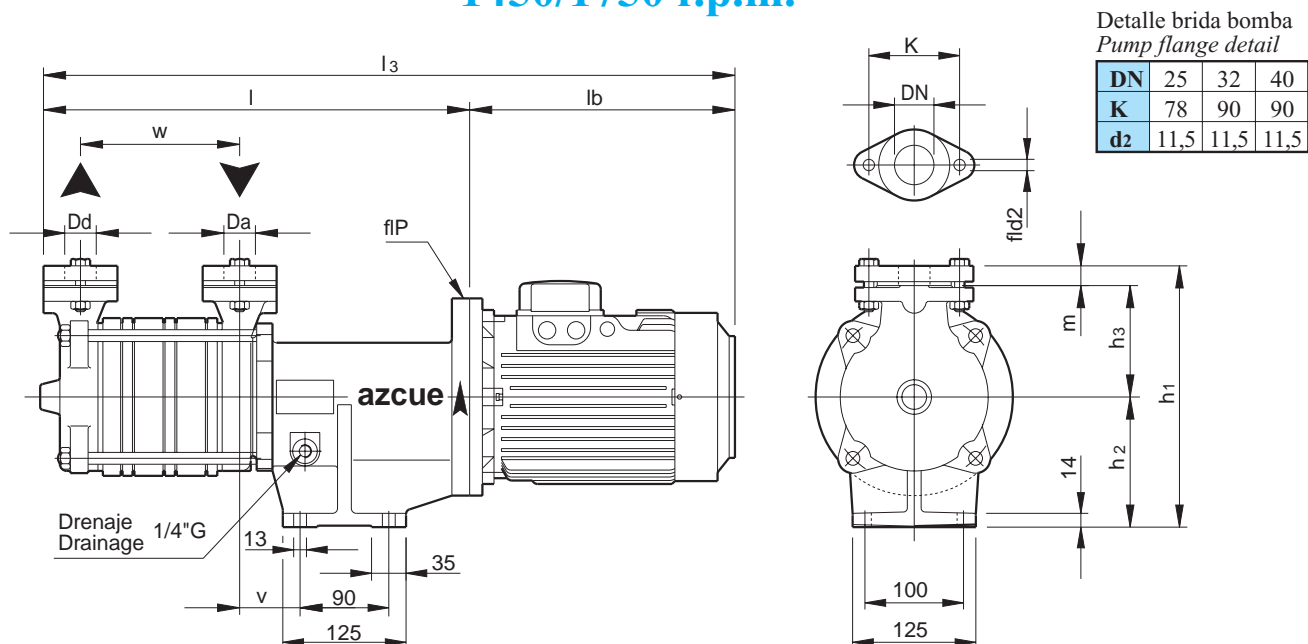

Ref. MO11-36-073

Tipo/Type MO	Motor/Moteur			Da	Dd	DN	h <sub>1</sub>	h <sub>2</sub>	h <sub>3</sub>	v	m	p	w	l	lb	l <sub>3</sub>	Kg									
	KW	HP	Tipo																							
11/10 12/10	0.5	0.75	80-a	1" G	1" G	25	222	112	90	63	20	200	76	336	235	571	31									
	0.75	1	80-b												235	571	32									
11/20 12/20	0.5	0.75	80-a												235	605	33									
	0.75	1	80-b												235	605	34									
11/30 12/30	1.1	1.5	90-S												270	640	37									
	0.75	1	80-b												235	639	36									
	1.1	1.5	90-S										270	674	39											
11/40 12/40	1.5	2	90-L										270	674	42											
	1.1	1.5	90-S										270	708	41											
	1.5	2	90-L										270	708	44											
19/10	0.75	1	80-b										1 1/4" G	1 1/4" G	32	257	132	105	61	20	200	80	355	235	590	38
	1.1	1.5	90-S																					270	625	41
19/20	1.1	1.5	90-S	270	661	44																				
	1.5	2	90-L	270	661	47																				
	2.2	3	100-L	310	701	52																				
19/30	1.5	2	90-L	270	697	50																				
	2.2	3	100-L	310	737	55																				
	3	4	100-L	310	737	58																				
19/40	2.2	3	100-L	310	773	58																				
	3	4	100-L	310	773	61																				
	4	5.5	112-M	310	773	64																				
31/10 36/10	0.75	1	80-b	1 1/4" G	1 1/4" G	40	265	132	113	60	20	200										87	362	235	597	39
	1.1	1.5	90-S										270	632	42											
	1.5	2	90-L										270	632	45											
31/20 36/20	1.5	2	90-L										270	672	48											
	2.2	3	100-L										310	712	53											
	3	4	100-L										310	712	56											
31/30 36/30	2.2	3	100-L										310	752	56											
	3	4	100-L										310	752	59											
	4	5.5	112-M										310	752	62											
31/40 36/40	2.2	3	100-L										310	792	59											
	3	4	100-L										310	792	62											
	4	5.5	112-M										310	792	65											

Sujeto a cambios / Subject to alterations / Sujet à des modifications

\*Opcional



# Serie BR/BR series

## Montaje eje libre / Bare shaft assembly / Montage arbre nu

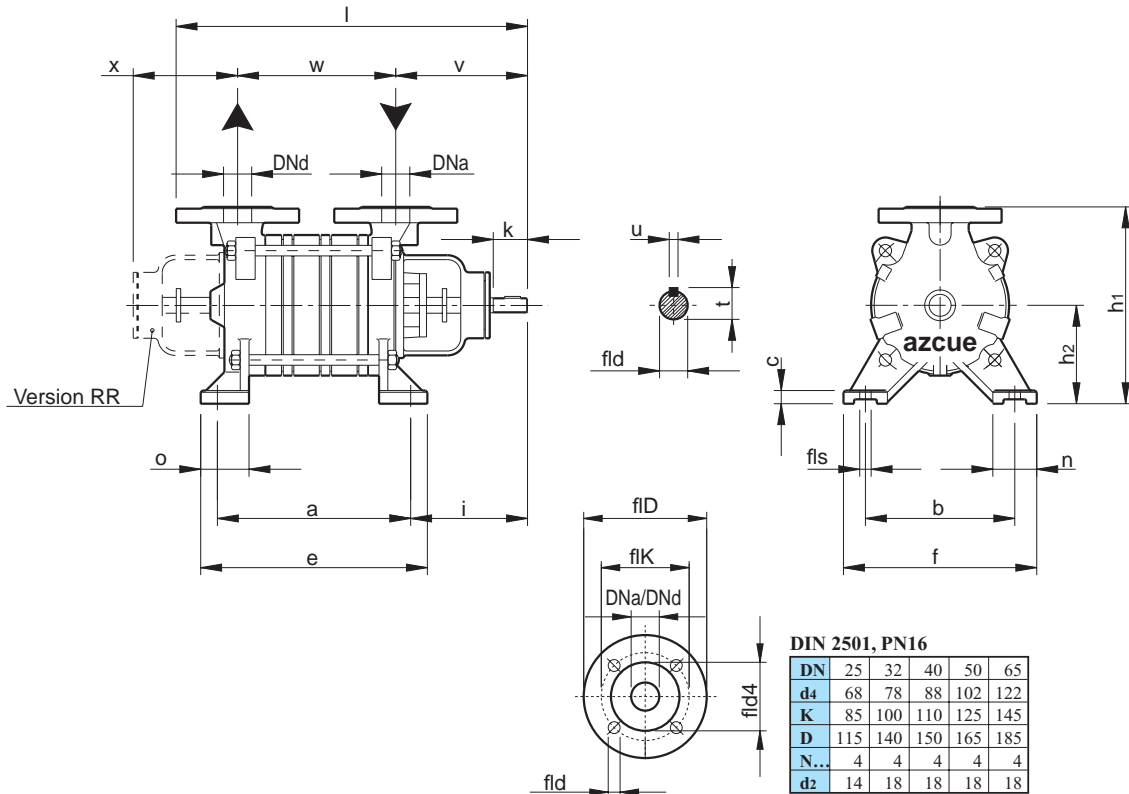

Ref. 543-BR19-71

Tipo/Type	DNa	DNd	f	b	n	s	c	h1	h2	k	d	t	u	i	v	o	x	a	e	w	l	kg
19/10*	25	25	155	120	36	13	13	205	100	40	14	16,1	5	152	166	50	130	150	186	122	350	19
19/20*																		186	222	158	385	22
19/30*																		222	258	194	420	25
19/40*																						
31, 36/10	32	32	220	160	50	13	15	224	112	40	16	18,1	5	135	154	55	125	180	218	144	368	25
31, 36/20																		220	258	184	408	30
31, 36/30																		260	298	224	448	35
31, 36/40																						
41/10	40	40	220	170	50	13	20	267	132	38	19	21,5	6	195	195	55	155	154	186	147	420	35
41/20																		207	239	200	473	41
41/30																		260	292	253	526	47
41/40																		313	345	306	579	53
51/10	50	50	220	160	55	13	20	290	150	40	22	24,9	8	195	205	55	165	184	218	167	455	45
51/20																		256	290	240	528	53
51/30																		329	363	313	600	67
71/10	65	65	250	200	50	15	20	300	150	56	28	30,9	8	217	240	64	210	228	278	190	525	50
71/20																		318	368	280	615	65
71/30																		408	458	370	705	80

\* Consultar disponibilidad / Availability advised / Consulter pour disponibilit e  
 Sujeto a cambios / Subject to alterations / Sujet des modifications



# Serie BR/BR series

## Grupo electrobomba / Electropump / Groupe electropompe

### 1450/1750 r.p.m.

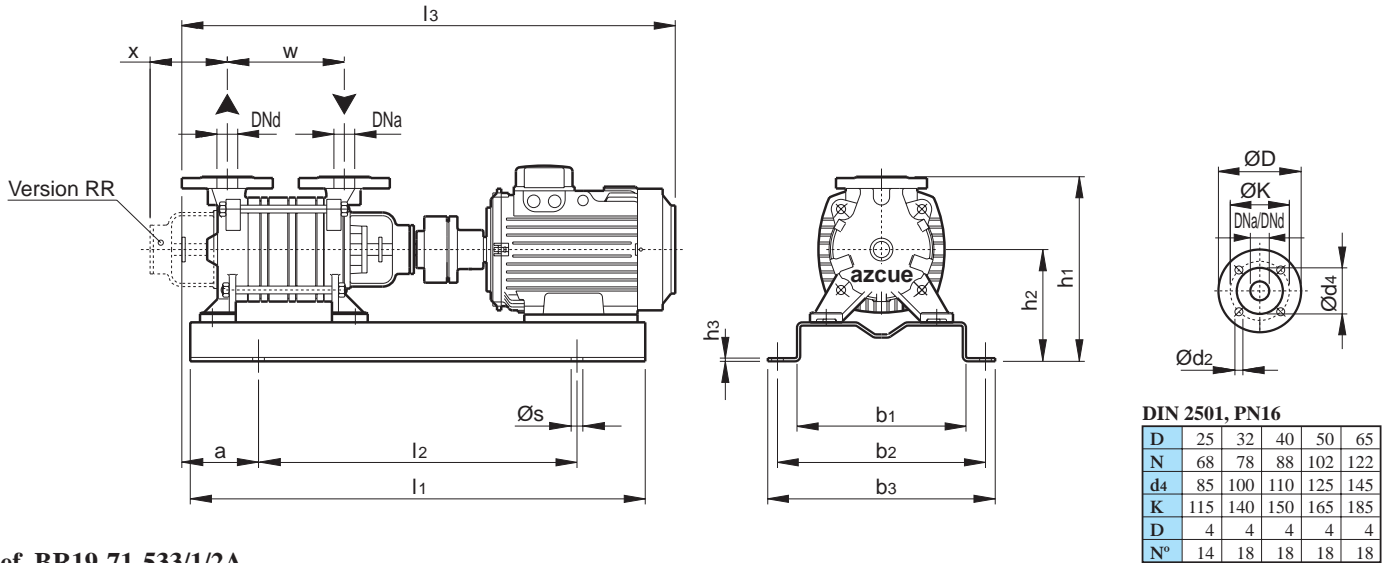

Ref. BR19-71-533/1/2A

Tipo/Type	Motor/Moteur			DNa	DNd	h1	h2	h3	b1	b2	b3	s	x	w	a	l1	l2	l3	Kg
	KW	HP	Tipo																
19/10*	0.37	0.5	71-b	25	25	245	140	7	230	270	300	18	130	122	125	600	380	610	37
	0.5	0.7	80-a															650	40
	0.75	1	80-b															650	40
19/20*	0.75	1	80-b	25	25	245	140	7	230	270	300	18	130	122	125	600	380	650	40
	1.1	1.5	90-S															650	40
	1.5	2	90-L															690	44
19/30*	1.1	1.5	90-S	25	25	245	160	7	270	320	350	18	130	158	120	700	490	720	50
	1.5	2	90-L															720	52
	2.2	3	100-L															760	57
19/40*	1.1	1.5	90-S	25	25	245	160	7	270	320	350	18	130	194	120	700	490	760	53
	1.5	2	90-L															760	55
	2.2-3	3-4	100-L															800	68
31, 36/10	0.5	0.7	80-a	32	32	264	152	7	230	270	300	18	125	144	130	600	380	670	45
	0.75	1	80-b															670	52
	1.1	1.5	90-S															710	52
31, 36/20	1.1	1.5	90-S	32	32	264	152	7	230	270	300	18	125	144	125	700	490	710	54
	1.5	2	90-L															710	54
	2.2	3	100-L															750	54
31, 36/30	1.1	1.5	90-S	32	32	264	172	7	270	320	350	18	125	144	125	700	490	750	60
	1.5	2	90-L															750	60
	2.2-3	3-4	100-L															790	66
31, 36/40	2.2-3	3-4	100-L	32	32	264	172	7	270	320	350	18	125	184	125	700	490	810	73
	4	5.5	112-M															830	75
	2.2-3	3-4	100-L															850	80
41/10	1.1	1.5	90-S	40	40	327	192	7	270	320	350	18	155	147	160	700	490	760	62
	1.5	2	90-L															760	64
	2.2	3	100-L															800	75
41/20	1.5	2	90-L	40	40	327	192	7	270	320	350	18	155	200	160	700	490	815	70
	2.2-3	3-4	100-L															855	80
	4	5.5	112-M															875	91
41/30	2.2-3	3-4	100-L	40	40	327	192	7	270	320	350	18	155	253	205	800	500	910	87
	4	5.5	112-M															930	96
	5.5	7.5	132-S															900	600
41/40	3	4	100-L	40	40	327	192	7	270	320	350	18	155	306	205	900	600	1030	107
	4	5.5	112-M															960	100
	5.5	7.5	132-S															980	106
51/10	7.5	10	132-M	50	50	350	210	7	270	320	350	18	165	306	205	1000	690	1085	117
	2.2-3	3-4	100-L															1085	127
	4	5.5	112-M															835	86
51/20	4	5.5	112-M	50	50	350	210	7	270	320	350	18	165	167	205	800	500	855	95
	5.5	7.5	132-S															855	95
	7.5	10	132-M															930	102
51/30	7.5	10	132-M	50	50	350	220	7	310	360	390	18	165	240	205	1000	690	1030	116
	11	15	160-M															1030	126
	15	20	160-L															1155	148
71/10	7.5	10	132-M	65	65	360	210	7	310	360	390	18	210	313	205	1100	690	1100	143
	11	15	160-M															1230	163
	15	20	160-L															1275	178
71/20	3	4	100-L	65	65	360	210	7	310	360	390	18	210	190	205	1000	690	905	100
	4	5.5	112-M															935	107
	5.5	7.5	132-S															1010	118
71/30	7.5	10	132-M	65	65	360	210	7	310	360	390	18	210	280	205	1000	690	1100	141
	11	15	160-M															1230	165
	15	20	160-L															1270	180
71/30	11	15	160-M	65	65	370	220	7	310	360	390	18	210	370	265	1200	700	1315	190
	15	20	160-L															1360	205
	18.5	25	180-M															1435	280
	22	30	180-L			390	240	7	380	440	470	18	210	370	265	1300	800	1435	300

\* Consultar disponibilidad / Availability advised / Consulter pour disponibilit e  
 Sujeto a cambios / Subject to alterations / Sujet   des modifications



**Tipo / Type MA-80**  
**N. OMA-328-M**

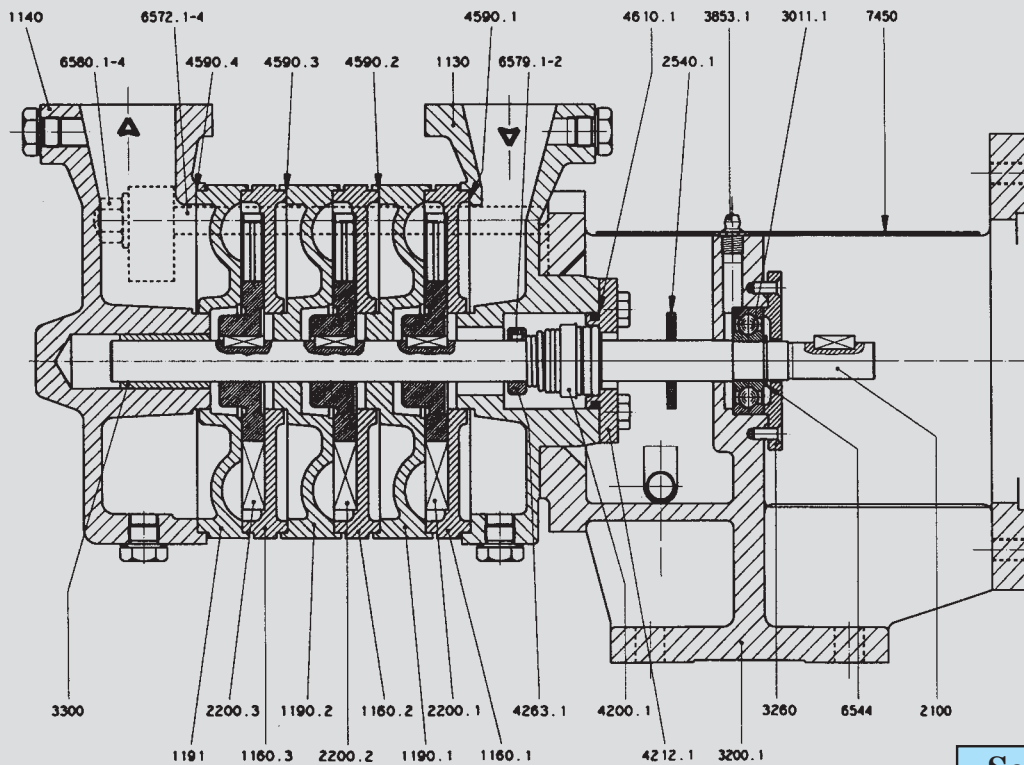
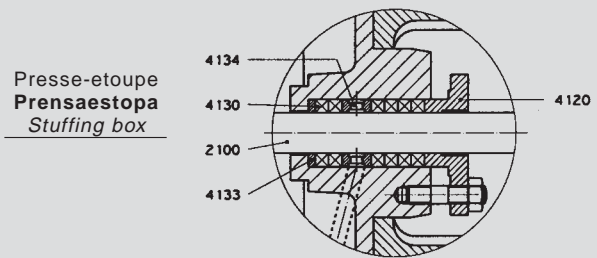
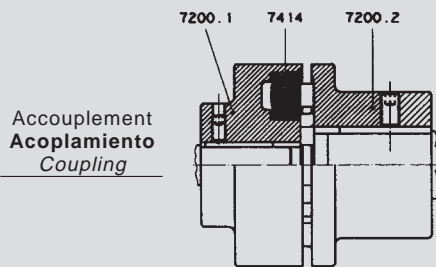
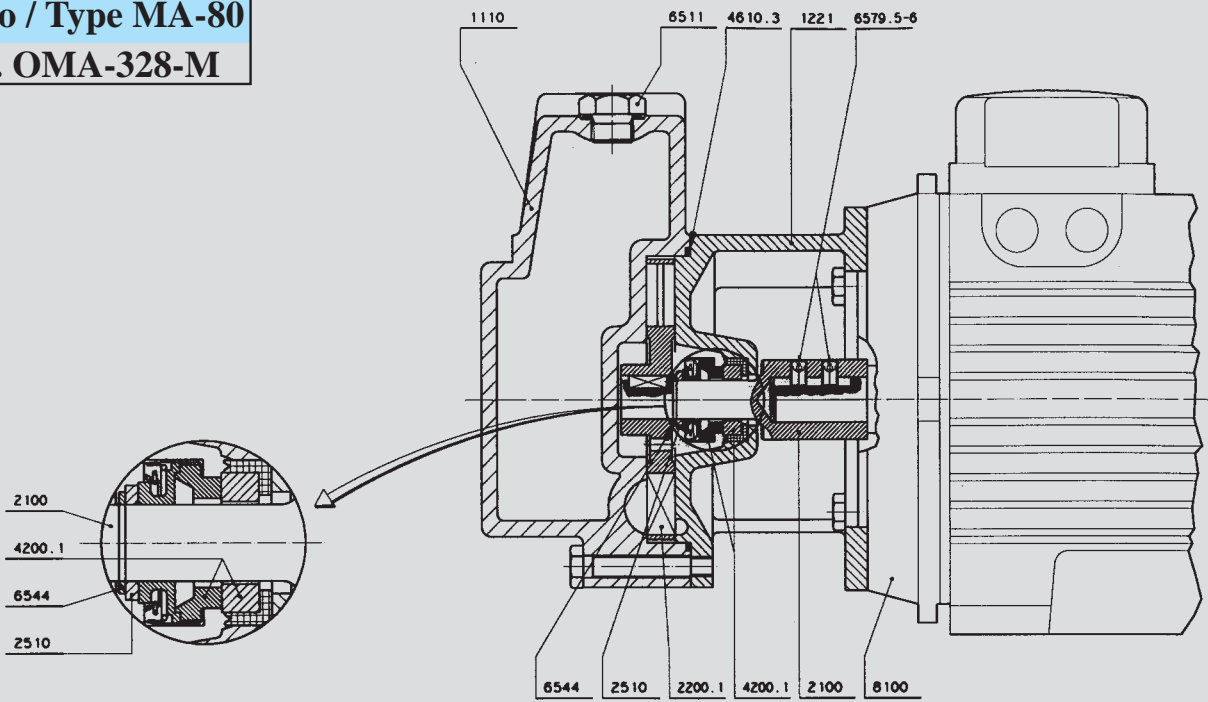

**Serie MO Series**  
**N. SP-338-M**



Serie BR Series  
N. SP-337-M

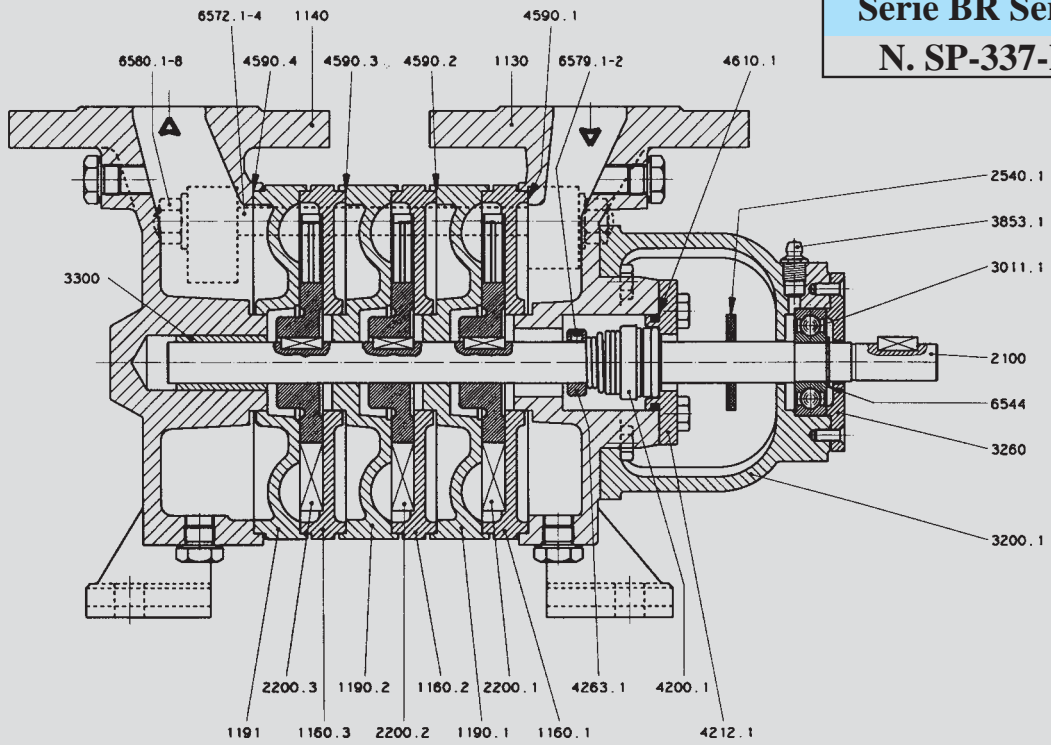

Accouplement  
Acoplamiento  
Coupling

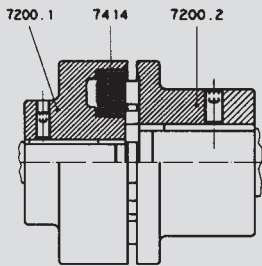

Presse-étoupe  
Prensaestopa  
Stuffing box

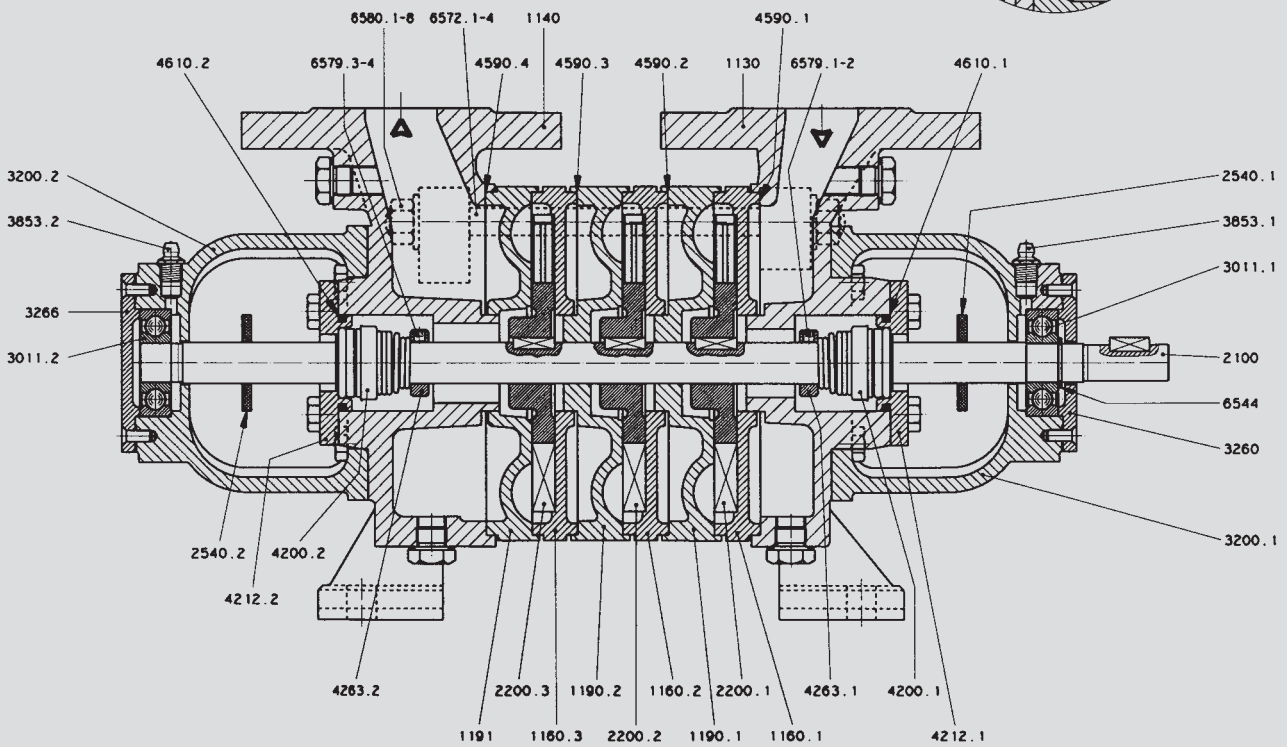
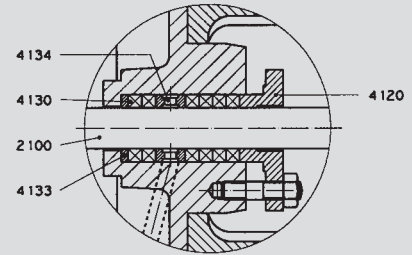

Serie BO-BR...-RR Series N. SP-336-M



<b><i>DENOMINACION / DESCRIPTION / DENOMINATION</i></b>	<b><i>Ref</i></b>
Cuerpo de bomba / Pump casing / Corps de pompe	1110
Cuerpo de aspiración / Suction casing / Corp's d'aspiration	1130
Cuerpo de impulsión / Delivery casing / Corp's de refoulement	1140
Difusor de aspiración / Suction diffuser / Diffuseur d'aspiration	1160.1-3
Difusor de impulsión / Descharge diffuser / Diffuseur de refoulement	1190.1-2
Difusor de impulsión última etapa / Diffuser last stage / Diffuser dernier etape	1191
Tapa del cuerpo / Casing / Couvercle	1221
Eje / Shaft / Arbre	2100
Rodete / Impeller / Roue	2200.1-3
Anillo distanciador / Spacer ring / Bague-entretoise	2510
Deflector / Thrower / Deflecteur	2540.1-2
Rodamiento radial de bolas / Radial ball bearing / Roulement a billes	3011.1-2
Cuerpo del soporte / Bearing housing / Corps de palier	3200.1-2
Tapa del soporte / Bearing cover / Couvercle de palier	3260
Tapa del soporte final / Bearing end cover / Couvercle de palier d'estremite	3266
Cojinete / Bearing bush / Coussinet	3300
Racor de engrase / Grease nipple / Graisseur	3853.1-2
Cierre mecánico / Mechanical seal / Garniture mecanique	4200.1
Cierre mecánico / Mechanical seal / Garniture mecanique	4200.2
Platillo del cierre mecánico / Seal cover / Couvercle d'etancheite	4212.1-2
Arandela de apoyo del muelle / Spring plate / Rondelle d'appui du ressort	4263.1-2
Junta plana / Gasket / Joint plat	4590.1-4
Junta tórica / O-ring / Joint torique	4610.1-2
Junta tórica / O-ring / Joint torique	4610.3
Tapón de llenado / Priming plug / Bouchon de remplissage	6511
Circlip	6544
Espárrago / Stud / Goujon filete	6572.1-4
Tornillo de exágono interior / Socket head cap screw / Boulon à six pans creux	6579.1-4
Tornillo de exágono interior / Socket head cap screw / Boulon à six pans creux	6579.5-6
Tuerca / Nut / Ecrou	6580.1-8
Semi-acoplamiento / Coupling half / Demi-accouplement	7200.1
Semi-acoplamiento / Coupling half / Demi-accouplement	7200.2
Amortiguador de acoplamiento / Coupling bush / Garniture de broche d'accouplement	7414
Protección del acoplamiento / Coupling guard / Protecteur d'accouplement	7450
Motor / Moteur	8100
<b>Con prensaestopa / Stuffing box / Presse-etoupe</b>	
Brida prensaestopa / Stufing box gland / Fouloir	4120
Empaquetadura del prensaestopa / Gland packing / Garniture de presse-etoupe	4130
Anillo de fondo / Packing seating ring / Grain de fond	4133
Anillo de cierre / Lantern ring / Lanterne d'arrosage	4134

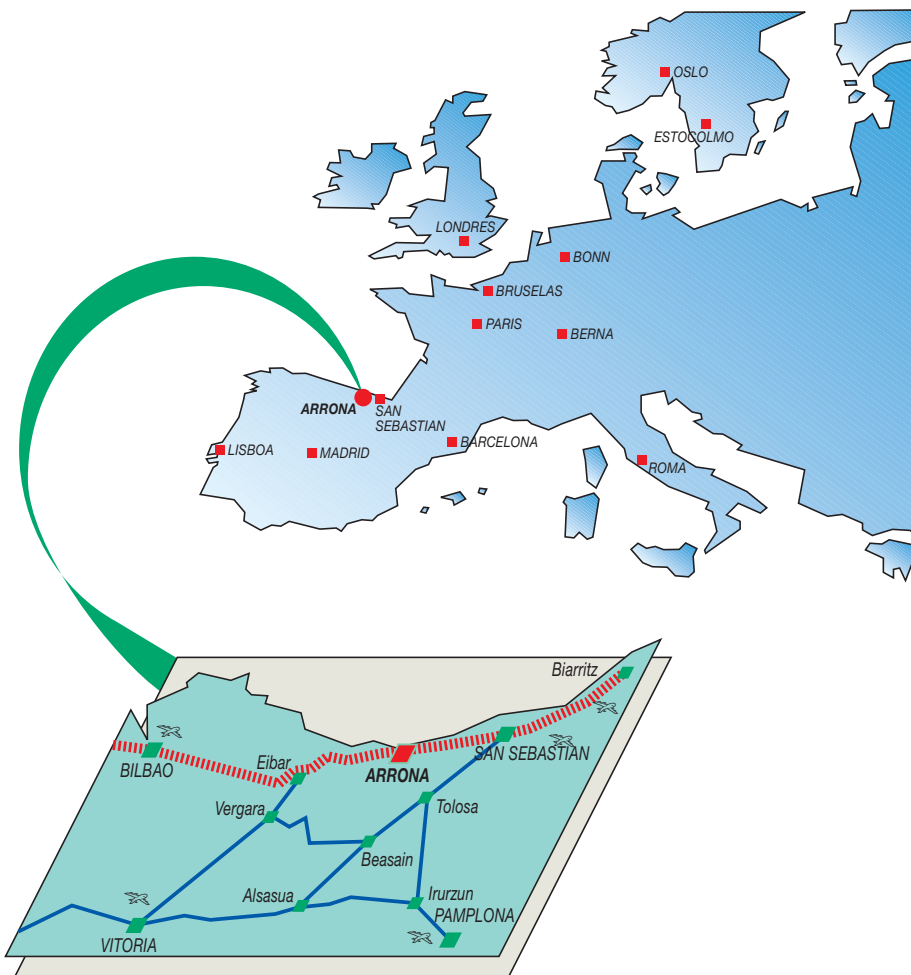

pumps pumps  
**azcue**  
 bombas pumpen

**FABRICA Y OFICINAS**  
**FACTORY AND HEAD OFFICE**

Tel.: 943 14 70 47\* • Fax: 943 14 74 40  
 Email: [comercial@azcuepumps.es](mailto:comercial@azcuepumps.es)  
 ARRONA - CESTONA (Guipúzcoa) España

**DIRECCION POSTAL**  
**P. O. BOX**

Apartado de Correos, 34  
 20750 ZUMAIA  
 (Guipúzcoa) España